

# E-LIFE EPC-716

## Endüstriyel Panel PC

### GENEL BİLGİ

- Intel Core i3-8145U ve i5-8265U İşlemci Seçenekleri
- Yeni Nesil Şık Tasarım ve Fansız Mimari
- Dayanıklı Alüminyum Gövde
- 15.6" ve 400 cd/m2 Parlaklıkta Endüstriyel Tip LCD Ekran
- 1920 x 1080 Full HD Ekran Çözünürlüğü
- Multi-Touch Projected Capacitive Dokunmatik Ekran
- 2 adet Gigabit Ethernet Portu
- 1 adet RS232/RS485 ve 3 adet RS232 Portu
- 2 adet USB 2.0 ve 4 adet USB 3.0
- 12V DC Güç Girişi
- Remote Power Switch Soketi
- CE Uygunluk Sertifikası
- 5 Yıl Garanti



e-life  
solutions



## Kompakt Boyutta Full HD Çözünürlük ve Core Mobil İşlemci Performansı E-Life EPC-716

Geniş ekranda Full HD çözünürlüğe, yüksek işlemci performansı ile ihtiyaç duyulan uygulamalar için geliştirilen E-Life EPC-716, şık tasarımı, gelişmiş özellikleri ve dayanıklı Projected Capacitive Dokunmatik Ekranıyla Türkiye'nin en güvenilir yerli Panel PC çözümü olarak tüm endüstriyel otomasyon ve dijital dönüşüm projelerinize güç katacak.

Türkiye'nin ilk orijinal Panel PC üreticisi olan şirketimizin, 2004 yılından günümüze ulaşan Panel PC tasarım ve üretim tecrübesi ile sahada kullanılan binlerce üründen edindiği geri bildirimlerin birleşimini yansıtan E-Life EPC Serisi Panel PC'lerin yeni üyesi EPC-716, otomasyon, veri toplama, operatör paneli ve HMI uygulamaları yanında sahip olduğu şık tasarımı ile farklı uygulamalar için de benzersiz bir seçenek oluşturuyor.

8. Nesil Intel Core i3-8145U ve i5-8265U işlemci seçenekleri ile gelen yeni EPC-716 Panel PC, en karmaşık uygulamalar için bile yüksek performans sunarak endüstriyel ortamlarda kesintisiz çalışma sağlıyor.



# Teknik Özellikler



# E-LIFE EPC-716

Endüstriyel  
Panel PC



## CPU

Intel® Core™ i3-8145U,  
2.10 GHz, 4 MB Smart Cache  
Intel® Turbo Boost Technology  
2.0 ile maks 3,90 GHz  
Intel® Core™ i5-8265U,  
1.60 GHz, 6 MB Smart Cache  
Intel® Turbo Boost Technology  
2.0 ile maks 3,90 GHz



## RAM

Standard 8 GB DDR4  
2400 MHz (Maks. 16GB)



## SSD

Standart 128GB M.2 SSD  
SATAIII Sürücü  
256GB - 1TB M.2 SSD  
SATAIII Sürücü Seçenekleri



## Ekran

15.6" TFT LCD



## Çözünürlük

1920 x 1080



## Parlaklık

400 cd/m2



## Kontrast

1000:1



## LCD İzleme Açısı (Y/D)

160°/140°



## Dokunmatik Ekran

Projected Capacitive,  
5 Nokta Multi-Touch,  
Eldivenli Kullanım Desteği\*



## Seri Port

1 x RS232/RS485  
1 x RS22323



## USB

2 x USB 2.0  
4 x USB 3.0



## LAN

2 x Intel i211 Gigabit Ethernet



## Ekran Çıkışı

2 x HDMI



## Ekran Kartı

Intel® HD 620 Graphics



## Ses Kartı

On board ALC662  
High Definition Audio



## Wi-Fi

Opsiyonel Wi-Fi Modülü ile  
IEEE 802.11 b/g/n,  
2dBi Wi-Fi Anteni



## Genişleme Yuvası

1 x M.2



## Güç Kaynağı

12V / 5A DC Adaptör



## Güç Girişi

12V DC



## PC Kasası

Alüminyum Gövde ve  
Elektro Statik Toz Boyalı Metal



## Montaj

VESA 100 x 100 Montaj Yuvaları  
Opsiyonel Panel Montaj Aparatı  
Opsiyonel Masaüstü ve Kiosk Tipi  
Ayak Seçenekleri



## Çalışma Sıcaklığı

0 ~ 60 °C



## Boyutlar

407 x 255 x 53 mm



## Ağırlık

5 Kg.



## Desteklenen İşletim Sistemi

Windows 10 IoT

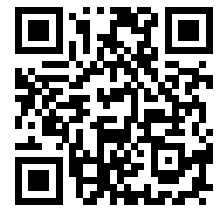
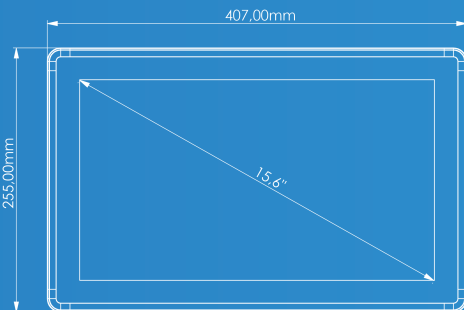

# NOYA

**NOYA DİJİTAL DÖNÜŞÜM  
TEKNOLOJİLERİ A.Ş.**

Hamidiye Mah. Soğuksu Caddesi  
No:5 Kat:8 34408 Kağıthane /  
İstanbul / Türkiye

☎ **0212 294 24 03**  
☎ **0850 399 66 92**

info@noyatech.com  
www.noyatech.com

Noya Dijital Dönüşüm Teknolojileri A.Ş. ürün özelliklerini haber vermeksizin değiştime hakkını saklı tutar.

\*Eldivenle kullanım desteği Latex, Nitril, PVC ve PU malzemeden yapılmış eldivenler için geçerlidir.